

City COLOR

PATENT SYSTEM

IP•54

INTERNATIONAL PATENT WO99/40361

User's and operator's manual for art. 0002•0003•0004•0005

Index

Safety informations	page 1
Technical features	page 2
Main supply connection	page 3
Lamp installation, replacement and setting	page 4
Installation of the dust proof filters	page 5
Control panel and configuration	page 6
Use of the CityColor in DMX 512	page 8
DMX signal connection	page 9
DMX line and terminator	page 10
Automode functioning	page 11
Appendix	page 12
Components and parts	page 14
Technical drawings	page 15
Electric diagrams	page 18
Troubleshooting	page 23
System board connection	page 25

City COLOR IP•54
PATENT SYSTEM

INTERNATIONAL PATENT WO99/40361





SAFETY INFORMATION

READ ALL CAUTIONS AND WARNINGS PRIOR TO OPERATE THIS EQUIPMENT.
INSTRUCTION TO PREVENT INJURY OR DAMAGE DUE TO ELECTRIC SHOCK, FIRE, MECHANICAL HAZARDS
AND UV RADIATION HAZARDS.

- **PROTECTION AGAINTS FIRE**

1) This equipment is designed for use with the following lamps only: MHD 1800W (art.0002) MHD 2500W and HMD 2500W (art.0003).

DO NOT USE ANY OTHER TYPE LAMP!

2) Maintain minimum distance of 0.5 meter from walls or any other type flammable surfaces.

3) Maintain minimum distance to lighted objects of 5.0 meter.

4) Replace fuses only with the specified type and rating.

5) Do not install the spot close to heat sources. Do not lay the connection cable on the spot when it is warm.

- **PROTECTION AGAINST ELECTRIC SHOCK**

1) This equipment must be earthed.

2) Class I equipment. The power supply cord includes a protective earthing conductor as part of the cord.

3) For connection to the supply mains proceed as pict.1 page 3. The equipment must be connected to branch circuit having a circuit- breaker In=16A Id=0.03A (230VAC) (art.0002 and art. 0005) or In=32A Id=0.03A (230VAC) (art.0003 and art. 0006)

4) Disconnect power before lamp's replacement or servicing (service personnel).

- **PROTECTION AGAINST MECHANICAL HAZARDS**

1) Use secondary safety chain when fixing this equipment.

2) Hot lamp explosion hazard. Do not open the equipment for 300 seconds after switching off.

3) Equipment surface may reach temperature up to 100°C. Allow about five minutes before handling.

4) Replace the lamp if it is damaged or thermally deformed.

- **PROTECTION AGAINST UV RADIATION HAZARDS**

1) Do not start on this equipment without lamp enclosure or if the protection screens, or ultraviolet screens are damaged.

2) The protection screens, the lenses, or the ultraviolet filters must be replaced if they are visibly damaged and their effectiveness has been reduced, for example, by cracks or deep scratches.

3) Do not look directly at the lamp while lamp is on.

INTRODUCTION

The CityColor projects, thanks to an extremely efficient optic system (international patent n. WO99/40361), a powerful light beam which can create numberless color shades. Its performances, in terms of luminosity and lighted surfaces, can reach incredible levels.

The CityColor IP54 comes in four versions:

- Art. 0002 CITYCOLOR for MHD 1800W discharge lamp
- Art. 0003 CITYCOLOR for MHD 2500W or HMD 2500W discharge lamp
- Art. 0005 CITYCOLOR for MHD 1800W discharge lamp Touring (with separate ballast)
- Art. 0006 CITYCOLOR for MHD 2500W or HMD 2500W discharge lamp Touring (with separate ballast)

The CityColor can work in automatic mode or in synchro mode, otherwise may be controlled by 8 bit DMX controllers

The input protocol is the DMX 512. To drive the CityColor we suggest to use either our controller DMX Control Spot, the Control Show 512 the Easy Control or the Fancy.

To make the most of its possibilities and for a correct functioning of this unit in the years to come, we suggest you to read carefully this manual before connecting or putting the spot into use. By doing so you will gain experience with its commands and connections and you will be easily able to use it.

CIRCUIT - BREAKER		
MAINS VOLTAGE	In	Id
230V	32A	0.03A

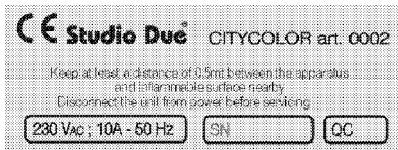

CONDUCTOR SIZES (length < 20mt.)	
MAINS VOLTAGE	CROSS SELECTIONAL AREAS
230V	3 x 1.5 mm ² (minimum)

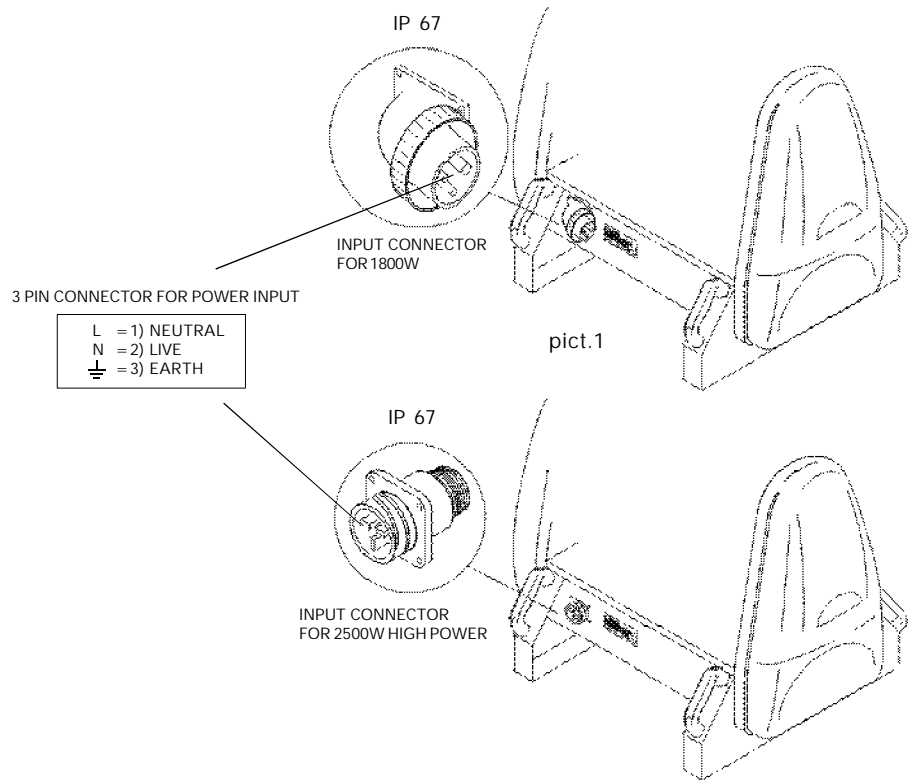

BEFORE USING



WARNING

The equipment must be earthed.

IP 54 grade: the equipment must be installed on the horizontal plane.

Read all cautions and warnings to page 1 prior to install this equipment. Particularly, read the follow:

- 1) Disconnect power before lamp's replacement or servicing (service personnel)
- 2) Do not open the lamp cover for 300 seconds after switching off
- 3) Wear gloves and goggles to re-lamping or to work inside the unit (service personnel)

Before connecting the equipment to the power system: make sure that the mains voltage and frequency correspond to rated values.

- The CityColor can be equipped for a mains voltage 230VAC, 50 or 60Hz
on request: 208Vac, 60Hz; 200Vac, 50Hz

For a power supply of 100V-120V it is necessary to use one auto transformer with the following features:

- Output voltage 230V
- Output current 15A (for art. 0002 - art. 0005)
- Output current 20A (for art. 0003 - art. 0006)

The power supply cords construction is shown in pict.1. For connection to the mains supply proceed as pict.1.

The equipment must be connected to branch circuit having a circuit-breaker In=16A • Id=0.03A (230VAC) (art. 0002 - art. 0005) or In=32A • Id=0.03A (230VAC) (art.0003 - art. 0006)

- a) Do not install the spot close to the heat sources. Observe minimum distance between the spots of 1.5 meters. Do not lay the connection cable on the spot when it is warm.
- b) This unit must be positioned as to allow its ventilation. Be careful not to occlude the in-out ventilating grilles.
- c) The unit must be positioned at least 50cm. from walls or other flammable surfaces.
- d) Observe minimum distance to lighted objects of 5 meters.

External surface temperature Ta 35°C:

- After 5 minutes work; Tc=75°C.
- Once the thermic balance has been obtained; Tc=100°C.

- 4) The protection screens, the lenses, or the ultraviolet filters must be replaced if they are visibly damaged and their effectiveness has been reduced, for example, by cracks or deep scratches.
- 5) The lamp must be replaced if it has been damaged or thermally deformed.
- 6) Clean regularly the in-out ventilating grilles.
- 7) Do not handle the spot by taking it by the head, but always by using the special handles.

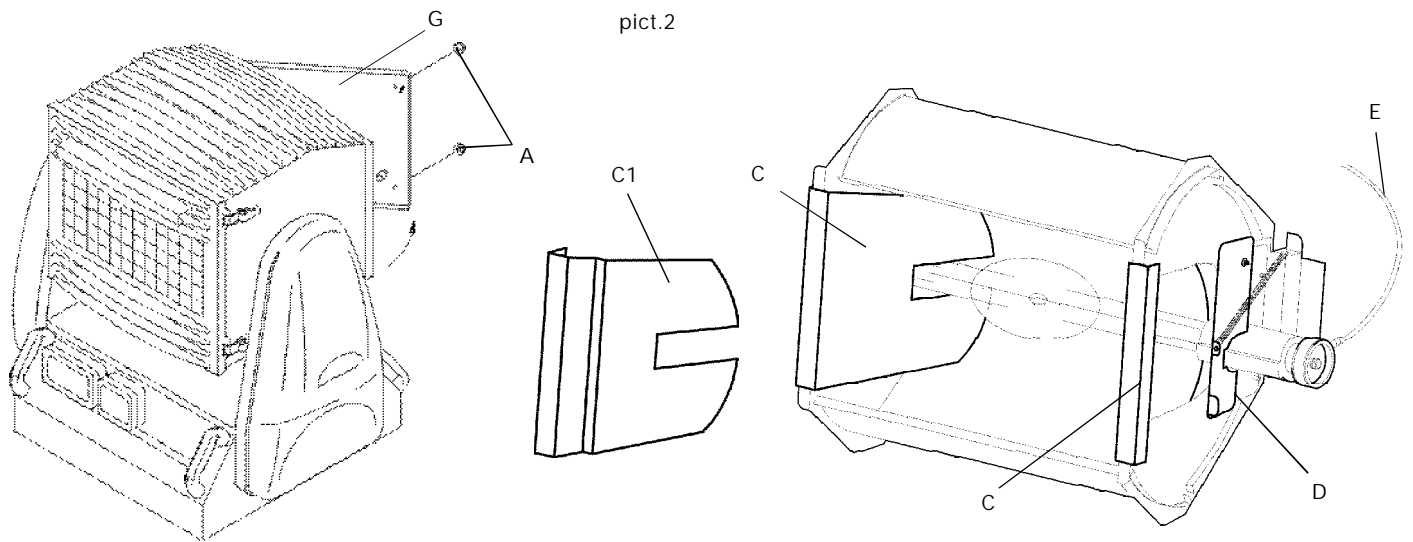

WARNING

In case of replacement of the lamp or maintenance, do not open the fixture unless 5 minutes have passed from the switching off. This operation has to be done when the apparatus is disconnected from the mains supply

INSTALLATION OF THE DISCHARGE LAMP MHD 1800W, MHD 2500W e HMD 2500W (art. 0002 - 0003 - 0005 - 0006)
(see pic.2)

- 1) Disconnect power before lamp's replacement. Wear gloves and goggles.
- 2) Remove completely the pommels (A) on the base of the head
- 3) Open the base of the lamp room (G)
- 4) Remove the two lateral reflectors (C1) or (C)
- 5) Lift up the two lampholder (D)
- 6) Install the new lamp. Taking care that protuberance of the bulb is set towards the reflector
Do not touch the quartz bulb with fingers. If this happens, clean the bulb before use with dry cloth and alcohol.
- 7) Put down the two upper lampholders (D)
- 8) Connect the cables (E) to the two ends of the lamp (MHD1800 or MHD2500) or connect the two cables of the lamp to the two red insulators on the rear panel of the head.
- 9) Put in again the two lateral plane reflectors. To obtain a wider optic (beam) use the C1 shaped reflectors. For a narrow optic (beam) use the C flat reflectors.
- 10) Close the rear panel and install again the two pommels (A) and hold them tightly.

IP RATE

The declared IP rate of the CityColor comes supported at these conditions:

- the installation of the fixture on a wide and stable surface
- the air cooling input and output are located on the base of the side-shell, it is not possible to install the fixture outdoor with the ballast upwards
- you must use the filter supplied with the basic kit for the IP RATE 54

WARNING

The CityColor has a IP rate 44 without filters installed and an IP RATE 54 with filters installed. You must use the filters in critical working conditions and, normally, when the fixture works outdoor.

You must remove the filters when the ambient temperature is over 35°C.
You must regularly clean the filters to allow the correct cooling of the fixture.

INSTALLATION OF THE DUST PROOF FILTERS

WARNING

You must operate with power supply disconnected from the fixture

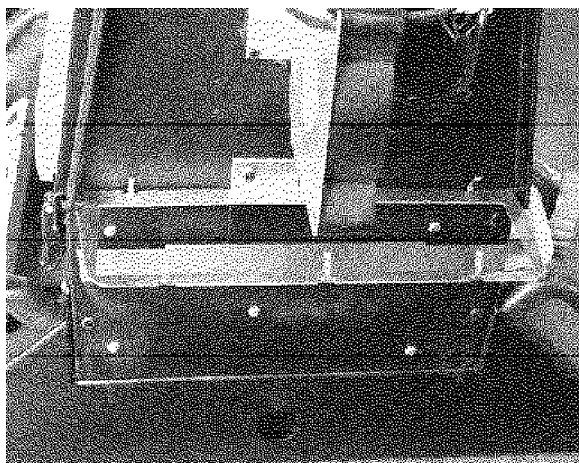

pict.3

You must remove the two side protective shells. The two filters must be assembled on the bulkheads at the bottom of the side brackets.

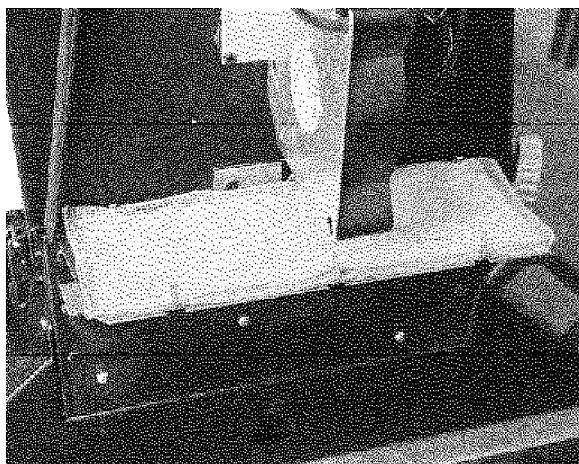

Pay attention to the installation: dust proof filters must stick correctly to prevent the entrance of the dust. You must control that the two filters completely cover the overall of the air entrance.

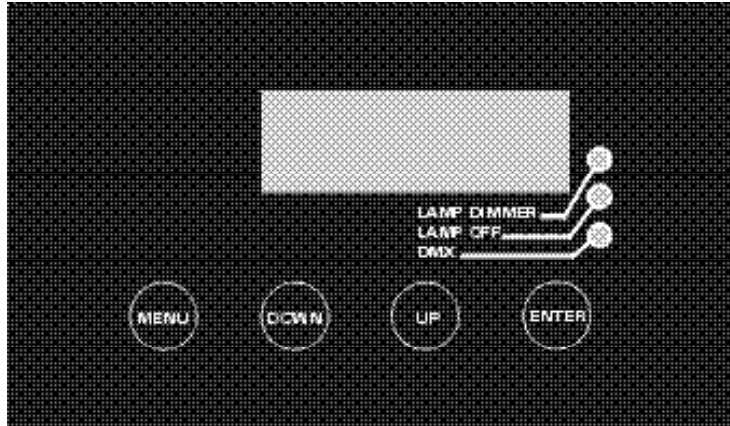

pict.4

CONTROL PANEL

On the control panel of the CityColor (pict.4) you can find, besides the display, the leds and the buttons to use to set the spot.

LED

- "DMX" led flashing: DMX input present
 off: no DMX input
- "LAMP" led flashing: the lamp switching off is remotely controlled
 off: lamp switched on
- "DIMMER" led flashing: the lamp is 33% dimmered
 off: lamp switched on

BUTTONS

Four buttons are used to programme the spot:

- MENU to select the programming options
- DOWN to go backward in the selected options
- UP to go forward in the selected options
- ENTER to confirm the selected options

DISPLAY

Shows the various menus and the selected options.

SUMMARY OF THE PROGRAMMING FUNCTIONS OF THE CITYCOLOR



Addr



NChn



Mode



Test



LHrs



FLIP



FHrs



Rset

About twenty seconds after the switching on, the number of the software version will be shown on the display in "X_00" format. Afterwards the first of the eight available menus will appear:

Addr to assign the DMX-512 address
Mode DMX512 mode, master with pre-set selection, slave
LHrs lamp working hours
FHrs fixture total working hours
NChn channels number
Test auto-test
FLIP display inversion
Rset reset of the spot

To select any of the given options, press the MENU button up to when the required one is shown.

Addr (Address)

To visualise the DMX address press ENTER.

To modify the address press Down and Up buttons and, once the required address has been selected, press and keep ENTER pressed up to when the display stops flashing (it flashes to indicate that the selected option is different from the pre-set one). To go back to the options without making any change, press the MENU button.

Mode (Mode)

To visualise this mode press ENTER.

Use Down and Up buttons to change the mode and, once the required one has been selected, press and keep ENTER pressed up to when the display stops flashing (it flashes to indicate that the selected option is different from the pre-set one). The available options are: no (normal) for the functioning in DMX reception; Pr01...Pr15 (pre-set 01...15) for the master functioning with the respective game, SL (slave) for the functioning as slave. To go back to the options without any change, press the MENU button.

LHrs (Lamp Hours)

To visualise the number of working hours of lamp press ENTER.

The maximum countable number of hours is 3000. Exceeding this number, the display will show gr3t (greater than 3 thousands). To reset the counter press simultaneously buttons Down and UP: the display will show CLLH (clear lamp hours). To go back to the options without making any change, press the MENU button.

FHrs (Fixture hours)

To visualise the number of working hours of fixture press ENTER.

The maximum countable number of hours is 3000. Exceeding this number, the display will show gr3t (greater than 3 thousands). To reset the counter press simultaneously buttons Down and UP. A control of the memory will be run and all the default settings will be stored: the display will then show Init. If the memory is damaged, the display will show the message FAIL. To go back to the options without making any change, press the MENU button.

NChn (Number of Channel)

To visualise the number of channel press ENTER.

Use Down and Up buttons to change the channel and, once the required one has been selected, press and keep ENTER pressed up to when the display stops flashing (it flashes to indicate that the selected option is different from the pre-set one). It is possible to set 6 channels or 7 channels (remote reset and remote lamp switch off). To go back to the options without making any change, press the MENU button.

Test (Autotest)

To insert the auto-test press ENTER and keep it pressed up to when the display shows the flashing message t-on (test on). To take off the auto-test press the MENU button. To go back to the options without making any change, press the MENU button.

FLIP (Display overturning)

The display visualisation can be standard or overturned: by pressing the ENTER button the two modes will be alternatively visible. The selected one will be immediately stored in the spot setting.

To go back to the options without making any change, press the MENU button.

Rset (Reset)

To run the complete reset press ENTER and keep it pressed up to when the display shows the flashing message r-on (reset on).

Once the reset procedure has been completed the spot will go back to the normal setting. To go back to the options without making any change, press the MENU button.

DRIVING THE CITYCOLOR WITH A DMX REMOTE CONTROLLER

- Select the requested DMX starting address by operating on the Addr option
- Select the requested number of channel with NChn option
- Connect the DMX signal between the fixture and the controller
- Check that the DMX led is flashing. (DMX signal present)
- If there is no signal, you must manually reset by operating on the RESET option

It is possible to choose a standard configuration occupying 6 DMX channels, or a enhanced configuration occupying 7 channels. Use the enhanced configuration if you want to activate channel 7 which enables the reset of the motors and the switching off of the lamp from the controller.

6/7 CHANNELS MODE SELECTION

Press the MENU button on the control panel up to when the option nChn is shown on the display, select it by pressing ENTER and the set indication will appear (6 or 7 channels). If you want to activate channel 7 you must set 6 channels on the display. Pass through the numbers by pressing the buttons UP and DOWN: once you have set the required number, store it by pressing the ENTER button and keep it pressed up to when the display stops flashing (the flashing shows that the selected option is different from the one previously stored). To exit from the selected option without making any change press the MENU button.

Here below is shown the complete list of the functions of the CityColor.

The complete list of the DMX values can be found in appendix "A", page 12

7 CHANNELS

CH 1= Speed
CH 2= Cyan
CH 3= Yellow
CH 4= Magenta
CH 5= Dimmer
CH 6= Basic colors+rainbow
CH 7= Reset/Lamp Off

6 CHANNELS

CH 1= Speed
CH 2= Cyan
CH 3= Yellow
CH 4= Magenta
CH 5= Dimmer
CH 6= Basic colors+rainbow

 **WARNING** When using CYM color mixing, the basic colors channel # 6 must be set at: 00=DMX value

CONNECTION THE DATA LINK (DMX 512)

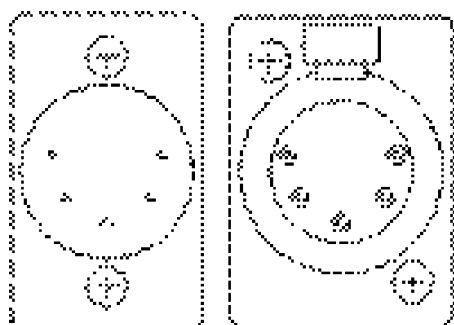

PIN	WIRE	SIGNAL
1	SHIELD	GROUND/RETURN/OV
2	INNER CONDUCTOR	DATA COMPLEMENT [-, INVERTED]
3	INNER CONDUCTOR	DATA TRUE (+, NON INVERTED)

pict.5a

pict.5

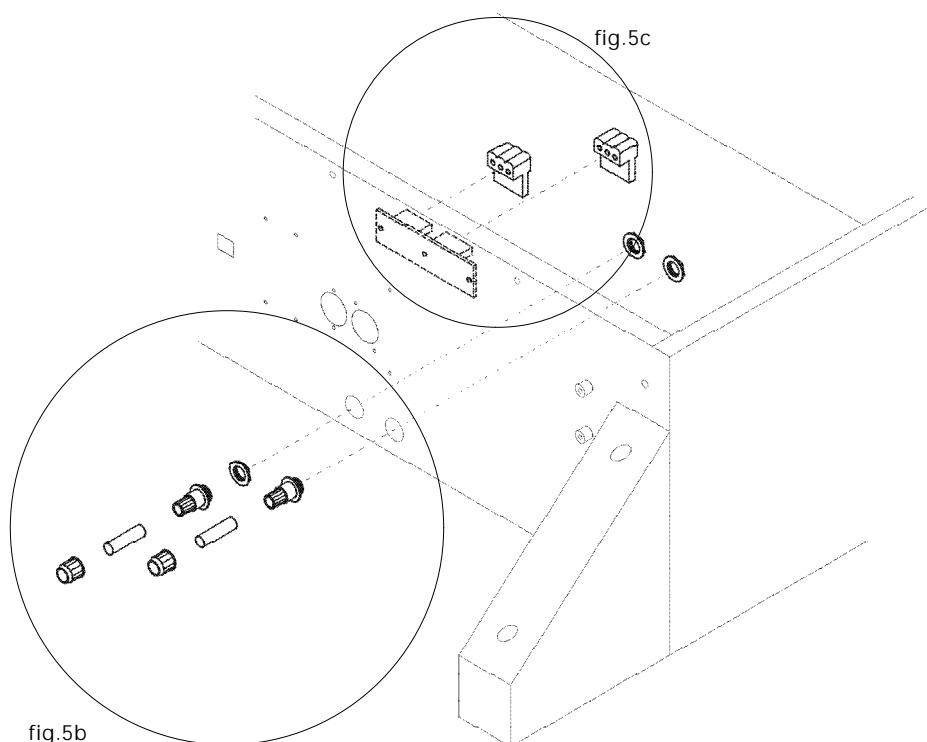

The connection of the DMX signal to the CITYCOLOR must be made by using the signal input XLR 5 pin connectors which are located on the control panel of the fixture. (pict.5)

The pin nomenclature of the connectors for the connection to the DMX signal is listed in the table. (pict.5a)

In order to avoid any problem in the signal transmission, it is warmly suggested to use a cable for high speed data transmission (sect. > 2x0.25 + gnd).

If the lines have a total length over 150-200 mts it is suggested to use a signal amplifier (art. 3004 - DMX repeater amplifier). The usage of a normal microphonic or audio cable is suggested only for lines max 100 mts long.

To ensure the IP54 rate you must connect the DMX cable inside the base. Use the given cables fixing (pict. 5b) and connect by following the cables numbering (pict. 5c).

DMX TERMINAL LINE



The wrong connection of the terminal line or its non-connection are probably the most frequent reasons for the defective functioning of the DMX line. The terminator is a resistor fitted between the two "data" lines (pins 2 and 3 of an XLR 5 pin connector) at the end of the cable furthest from the transmitter. The terminator resistor should have the same value as the impedance of the connection cable. We supply a terminal with a 100 Ohm resistor.

It is recommended that all DMX 512 systems have the termination resistor at the end of the line.

EXAMPLE 1
Connection controller-spot with 1 DMX 512 output

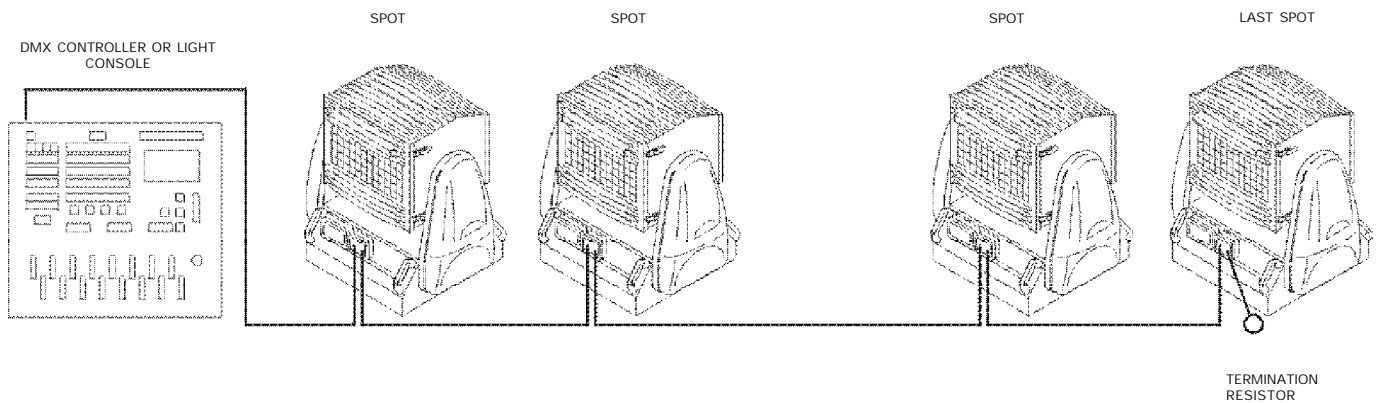

EXAMPLE 2
Connection controller-spot to one DMX 512 output over 150mts long

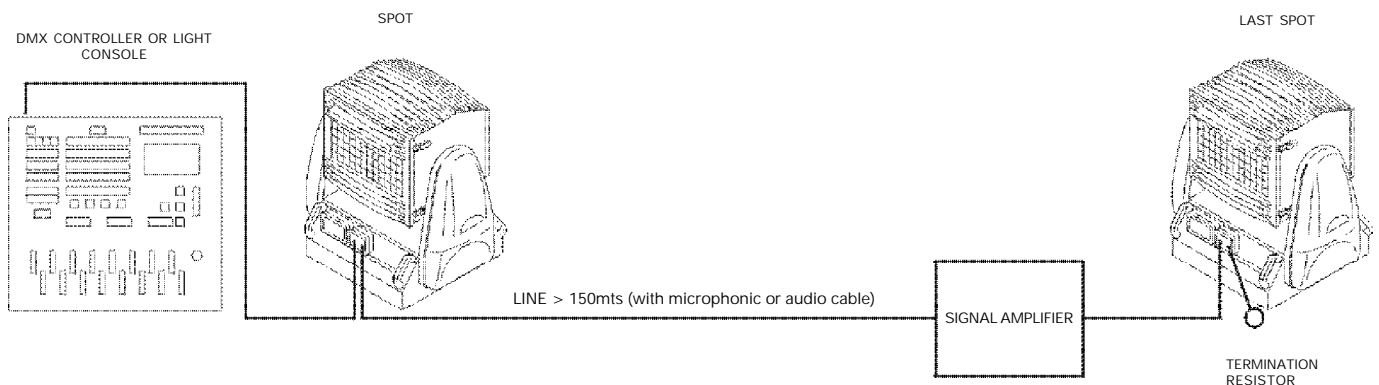

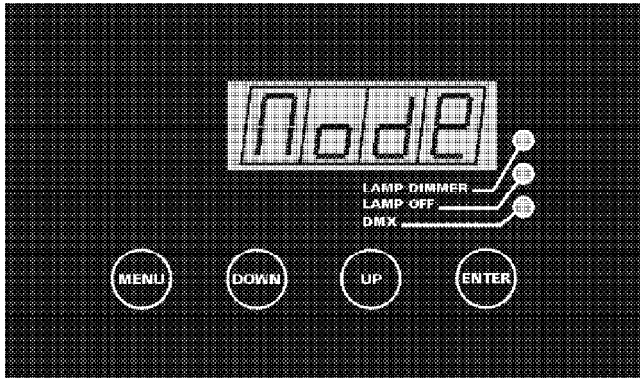

pict.7

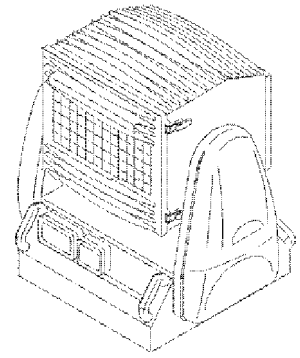

MASTER

USE OF THE CITYCOLOR IN AUTO-MODE

A short list of the games can be found in appendix "B", page 13

Press the MENU button on the control panel up to when the option MODE (pict. 7) is shown on the display, select it by pressing ENTER and the set indication will appear (no...SL). Use Down and Up buttons to change the mode and, once the required one has been selected, press and keep ENTER pressed up to when the display stops flashing (it flashes to indicate that the selected option is different from the pre-set one). The available options are: no (normal) for the functioning in DMX reception; Pr01...Pr15 (pre-set 01...15) for the master functioning with the respective game, SL (slave) for the functioning as slave. To go back to the options without any change, press the MENU button.

Mode	no	use of the CityColor in DMX-512
	Pr1..Pr15	master functioning with execution of the 15 stored programme
	SL	use of the CityColor in SLAVE MODE

EXAMPLE OF CONNECTION AND SETTING OF 4 CITYCOLOR IN SYNCHRO - MODE

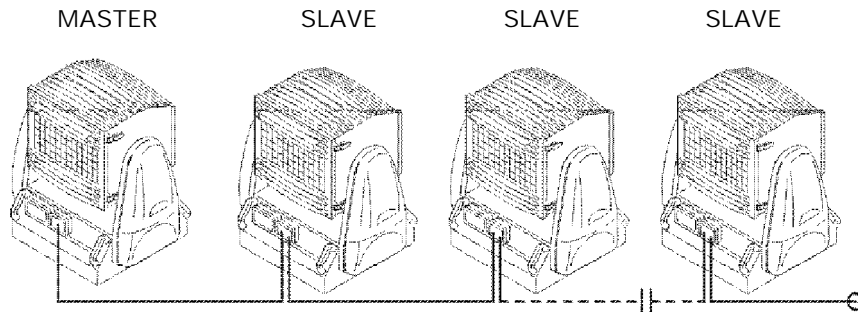

WARNING

I cavi e le connessioni sono gli stessi del DMX

EXAMPLE OF CONNECTION AND SETTING OF 4 CITYCOLOR IN INDEPENDENT AUTO - MODE

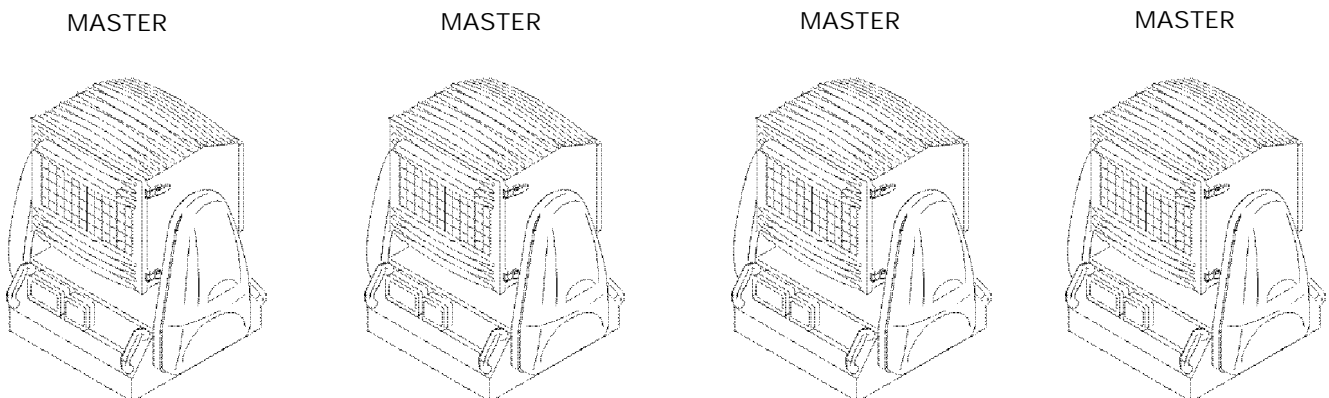

APPENDIX "A"

Here below you can find the complete list of DMX values (ref. page 8)

DMX CHANNEL	FUNCTIONS	DESCRIPTION	DECIMAL	PERCENT
1	MOTOR SPEED	MOVEMENT SPEED Slow Mid 2 Mid 1 Fast	0..63 64..127 128..191 192..255	< 25% 25%..50% 50%..75% > 75%
2	CYAN	CONTINUOUSLY VARIABLE White Full color	0 255	0% 100%
3	YELLOW	CONTINUOUSLY VARIABLE White Full color	0 255	0% 100%
4	MAGENTA	CONTINUOUSLY VARIABLE White Full color	0 255	0% 100%
5	DIMMER	CONTINUOUSLY VARIABLE Closed Full open	0 255	0% 100%
6	BASIC COLORS/ RAINBOW	Color mixing Cyan Yellow Magenta Blue Red Green Color mix sequence (slow) Color mix sequence (mid) Color mix sequence (fast)	0..25 26..51 52..77 78..103 104..129 130..155 156..181 182..207 208..233 234..255	0..10% 10%..20% 20%..30% 30%..40% 40%..50% 50%..60% 60%..70% 70%..80% 80%..90% 90%..100%
7	REMOTE RESET/ LAMP-OFF (optional)	Normal Reset (delay) Normal Lamp-off (delay)	0..127 128..191 192..250 251..255	0..50% 50%..75% 75%..98% 98%..100%

APPENDIX "B"

Here below you can find the complete list of the available games (ref. page 11)

PROGRAM	FUNCTIONS
01	Red Magenta Yellow - color mix sequence (slow)
02	Red Magenta Yellow + white color mix sequence (slow)
03	Green Cyan Yellow - color mix sequence (slow)
04	Green Cyan Yellow + white color mix sequence (slow)
05	Blue Cyan Magenta - color mix sequence (slow)
06	Blue Cyan magenta + white color mix sequence (slow)
07	All colors - color mix sequence (slow)
08	All colors + white color mix sequence (slow)
09	All colors - color mix sequence (mid)
10	All colors + white color mix sequence (mid)
11	All colors + white color mix sequence (mid+)
12	All colors - color mix sequence (mid+)
13	All colors + white color mix sequence (fast)
14	Basic colors (6 sec.)
15	Basic colors + white (6 sec.)

TROUBLESHOOTING GUIDE

Before calling for technical assistance, follow the recommended procedures in this appendix to solve many problems on your fixture.

CAUTION! • BEFORE YOU BEGIN:

Before you perform any troubleshooting procedures read the following personnel and equipment safety precautions:

- 1) Refer servicing to service personnel (Q.T.= qualified technician); no user serviceable parts inside
- 2) Wear hand and eye protection
- 3) Wait at least five minutes before accessing the lamp after operation
- 4) Disconnect the unit from power before removing any cover (Q.T.)

If the procedures do not solve your problem and you need to call for assistance, please provide the support technician with the following information:

- Customer name
- Phone number and fax number
- Fixture serial number
- Message that are you displayed on your Citycolor display
- Description of the problem and the troubleshooting procedures that you have performed so far to diagnose and resolve the fault.

You can contact your authorized STUDIO DUE dealer or directly STUDIO DUE I.d. Technical Service.
(fax. +39.0761.352653 - e-mail: service@studiodue.com)

GENERAL TROUBLESHOOTING

Appendix "C" • Table A1

Problem	Pilot-tests (guide)	Probable causes	Suggested solutions
The unit does not turn on, the fans do not work. The unit is completely dead	Measure the mains voltage on the main connector. If you have the right value the main fuses are blown	No power. Power cord or connectors. Main fuses blown.	Connect power. Replace the cables and the connectors. Replace the mains fuse
The fans work, the display is turned off (no reset when switching on, no light).	The electronics do not work. Check that the leds on the motor board (CCIP PCB) are turned on, particularly check the +5V.	Short circuit on the +5V line. D4 has blown. U12 short circuit or blown	General test on the +5V line. Replace the D4 diode. Replace the U12.
The unit works normally but the lamp does not turn on	When switching on, you can hear the click of the internal circuit breaker.	Bad lamp. Lamp is too hot to re-strike. Mains voltage is too low. The igniter is not working. Wrong ballast wiring.	Replace the lamp. Wait for the lamp cooling Measure the mains voltage. Replace the igniter. Check the ballast wiring
The unit works normally but the lamp does not turn on	When switching on, you can not hear the click of the internal circuit breaker.	The unit is not properly closed (cover and/or lamp house) Fault on wiring, PCB, switches	Check and close all the eight mechanical latches Carry out the tests shown on page 25
The unit works normally but the lamp does not turn on.	The thermal switch on the head of the fixture is open. The last DMX channel on the controller (n. 7) is set on a value >250	Too high temperature inside the head. The fan on the head is not working The air-in grilles are stopped up. The REMOTE LAMP OFF command is on.	Wait that the lamp housing has cooled down. Check and if necessary replace the fan. Check and if necessary replace the RFH resistor Clean the grilles Set the DMX channel on 0 value.

Ventilation of the head does not work normally	The electronic control of the fan is broken or not correctly connected	HEAD FAN connectors on the PCB CC are not ok U10 micro on the PCB CCIP broken	Check tension on the TO HEAD FAN connector Check the start-up test when switching on the fixture
Speed of the head fan is always the same	The electronic control of the fan is broken or not correctly connected	TO HEAD THERMAL SENSOR connectors are not ok Thermal sensor on the air output broken or disconnected U10 micro on the PCB CCIP broken	Check connections from TO HEAD THERMAL SENSOR connector to thermal sensor Check the thermal sensor Check the start-up test when switching on the fixture
The lamp is outting out intermittently	The lamp is not working well. The values reached by the internal temperature are too high	The tension of the power supply is either too high or too low. The fan on the head is not working regularly The air grilles are stopped up .	Measure the mains voltage. Check and if necessary replace the fan. Check and if necessary replace the RFH resistor Clean the grilles
One of the function is not working well(ie. DIMMER)	Disconnect the power. Manually test if the DIMMER moves freely.	The stepper motor is damaged or the cable connected to the controller pcb is broken (ref. CCIP PCB). The motor drive (L6219) is broken.	Make all the tests reported in page 25

DATA LINK (512 DMX) TOUBleshooting

Appendix "C" • Table A2

Problem	Pilot-tests (guide)	Probable cause(s)	Suggested Solutions
None of the Citycolors responds to controller. The DMX led is switched off.	Make sure that all the units are set in DMX mode. After the configuration reset all the fixtures	The controller is not connected to the fixtures. The cable from the controller to the first of the Citycolor is interrupted (or pin 2 and 3 are swapped or the cables are on short circuit)	Connect the controller properly. Use an already tested cable and connect the fixtures one by one.
One or more of the Citycolors do not respond to the controller or do it wrongly.	The non-working fixtures are always the same. The fixtures work accidentally. If one of the connecting cables is missing this may cause a random malfunctioning in addition to apparent normal operation. If the inverted-data is cut wire is cut (pin. 2 on the DMX connector) the line works intermittently.	Wrong DMX address in the fixture. Wrong data cables, or disconnected or shorted. One fixture has a broken DMX board. DMX link not terminated.	Set the proper address Check and if necessary replace the cables. Use a tested cable and replace only one at a time. Use a tested cable and exclude only one fixture at a time. Insert the terminator on the last fixture (pag.10)

MAIN BOARD CONNECTION

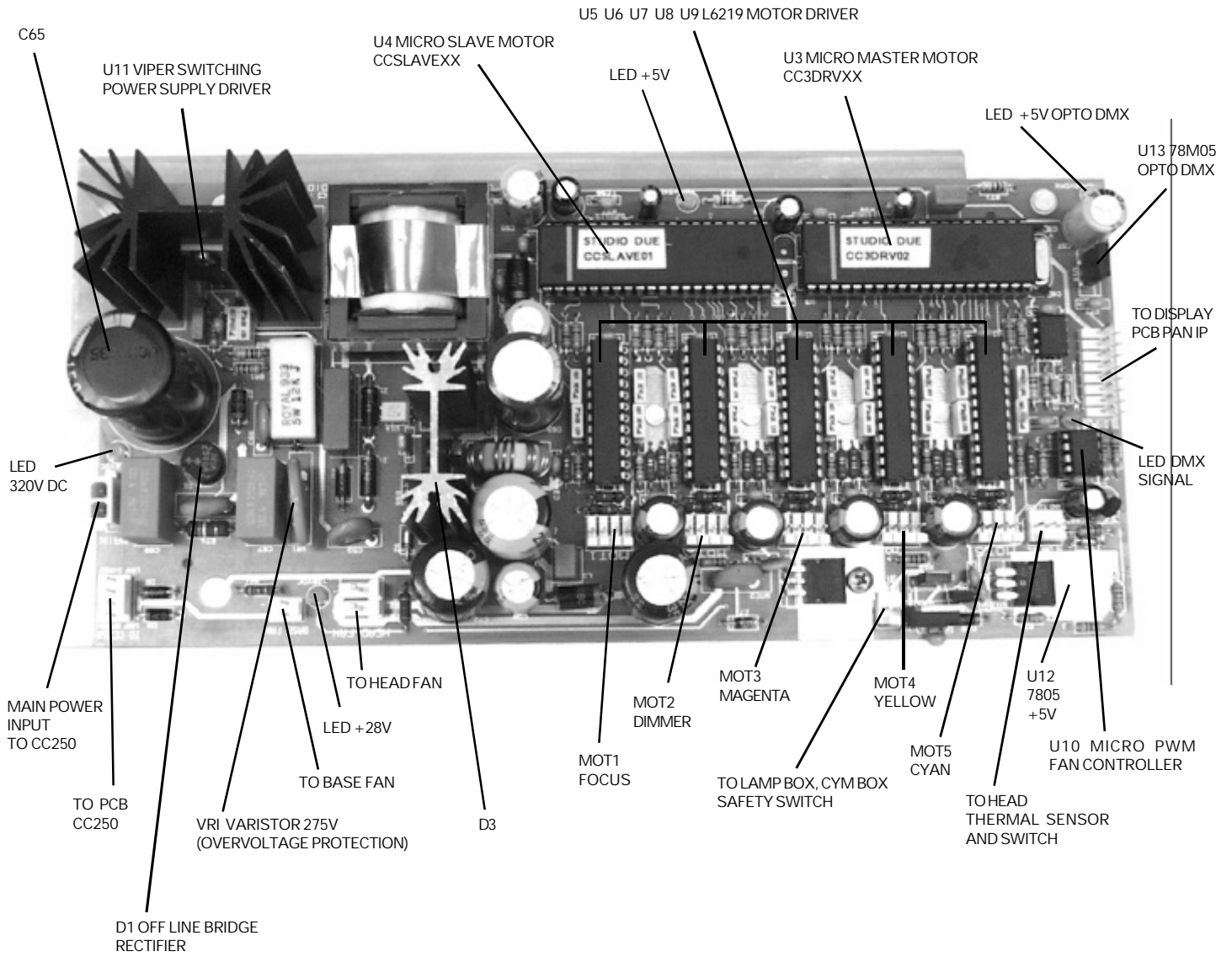

MOTORS BOARD

- POWER SUPPLY +30V Led On
 - +5V Led
 - +320V Led
 - +5V DMX Led
 - DMX signal
 - Led flashing: the DMX signal is operating on the board
 - Led off: check the U1 (6N137) and the DMX connecting cable (from PCB PAN IP)

- STEPPER MOTOR channel not working: (i.e. YELLOW):
 - 1) Switch off the fixture and disconnect the YELLOW and CYAN cables
 - 2) Connect the YELLOW cable on the CYAN connector
 - 3) Switch on the fixture:
 - 3a) If the YELLOW motor works normally it is necessary to replace the U6 (L6219)
 - 3b) If the motor is still not working check with extreme attention the motor and the interconnecting circuits (cables and connectors). To check the cables and the motors you can measure the resistance as follows:
between PIN 1 and PIN21 (on IC U6) $r = \sim 180\text{ohm}$; between PIN 2 and PIN5 (on IC U6) $r = \sim 180\text{ohm}$

- If the led +5V OPTODMX is off:
 - 1) Disconnect TO DISPLAY PCB PAN IP connector; if the led is on check PCB PAN IP
 - 2) Check U13 (78M05), L3, D6

- If the led +5V is off:
 - 1) Disconnect TO DISPLAY PCB PAN IP connector; if the led is on check PCB PAN IP
 - 2) Check D4, L2, U12

- If the led +28V is off:
 - 1) Check if the led +320V is on, if it is ok:
 - 1a) Check if U11 is in thermal drift (**ATTENTION on the heat dissipator there is dangerous tension!!!!**)
 - 1b) Check if U5, U6, U7, U8, U9 are in short-circuit. Switch off the fixture. Remove all the chips from the socket.
Switch on the fixture: if the led is on, insert the chips one by one in the sockets to find out which is in short-circuit.
 - 1c) Check D3
 - 1d) If all the operations described above have not given any positive result, change U11
 - 2) If the led +28V is off together with the led +320V
 - 2a) Check the MAIN POWER INPUT where you can measure the working voltage
 - 2b) Check the main fuse, if it is blown check VR1 (normally it has a resistance = ∞). If it is in short circuit you must change it.
 - 2c) Check D1 (Bridge Rectifier), if it is ok check C65.
 - 2d) If the fuse is still blown, change U11



Head Office: STUDIO DUE Light Division s.r.l.

Str. Poggino, 100 - 01100 Viterbo (Italy)
tel. +39 0761 352520
fax +39 0761 352653

Asia branch: STUDIO DUE Far East LTD

Unit D 29/F West Gate Tower
7 Wing Hong Street Kln. Hong Kong
tel. +852/29542141
fax +852/23302515

www.studiodue.com
info@studiodue.com
service@studiodue.com